



# Blowing machine mod. Lady

User & maintenance manual



Ver.3.0 – May 05 2023

Fibernet srl

Connectivity Solutions

[www.fibernet.it](http://www.fibernet.it)

## INDEX

<b>1.</b>	<b>GENERAL .....</b>	<b>4</b>
<b>2.</b>	<b>TECHNICAL CHARACTERISTICS.....</b>	<b>5</b>
2.1.	PRODUCT CONFIGURATION .....	6
2.2.	ACCESSORY KIT .....	7
<b>3.</b>	<b>OPERATING INSTRUCTION .....</b>	<b>9</b>
3.1.	PRELIMINARY OPERATIONS.....	9
3.2.	POSING PROCEDURE WITH COMPRESSED AIR .....	10
3.2.1.	CABLE AND DUCT POSITIONING .....	10
3.2.2.	AIR COMPRESSOR CONNECTION .....	14
3.3.	CABLE POSING.....	14
3.4.	CABLE POSING IN AN INTERMEDIATE STOP .....	16
3.5.	DISPLAY INFORMATION .....	20
3.6.	DRIVE BELTS HANDLING .....	21
<b>4.</b>	<b>MAINTENANCE.....</b>	<b>22</b>
4.1.	CLEANING .....	22
4.2.	DRIVE BELTS SUBSTITUTION .....	22
4.3.	SEAL ADAPTER GASKETS SUBSTITUTION .....	25
4.4.	BATTERY RECHARGING .....	27
<b>5.</b>	<b>CE DECLARATION OF CONFORMITY .....</b>	<b>28</b>

**SAFETY RULES**

Before performing any type of alteration and/or maintenance make sure to have previously disconnected the machine from all energy sources such as air compressor and USB port.



Air pressure shall never exceed the limit indicated in this user manual.



Do not open the lids of the blowing machine while operating with air compressor.



Before operating, make sure to have set and fixed the device on a solid surface. Check that the blowing machine is correctly connected to the minitube and that the cable is properly positioned between the two drive belts.



Before getting started, ensure that nobody is placed near the cable spools to avoid possible risks.



To avoid possible finger injury, make sure not to touch the cable when it is close to the working device; also ensure that the cable doesn't tangle up, causing hazard situations to the personnel involved.



Do not remove the plexiglass protections during posing operations (it could cause injuries to the hands).

## 1. GENERAL

Lady is a blowing machine entirely designed and developed by Fibernet Srl to blow cables inside minitubes.

The device is provided with a polypropylene waterproof case for a safe and easy transport and an accessory kit.

The machine is designed to be actuated by an external electric screwdriver equipped with a clutch or the dedicated electric motor.

To ease the blowing operation, the device can use the help of compressed air.



Figure 1: Fibernet blowing machine – Lady model.

#### FIBERNET SRL

Headquarters: Via degli Olmetti, 18 – 00060 Formello (RM) - Italy  
Share Capital € 100.000,00 - P.I. e C.F.: 06557181002 - Tel. +39 06 90405039  
[www.fibernet.it](http://www.fibernet.it); E mail: [info@fibernet.it](mailto:info@fibernet.it)

## 2. TECHNICAL CHARACTERISTICS

Lady blowing machine can be actuated by an external battery screwdriver equipped with a clutch, that operates the internal rubber belts transmission mechanism (LINATEX) specifically contoured to increase friction with the cable.



**Do not use electric screwdriver at a higher speed of 550 rpm/min.**



**Do not use drilling machine to operate the machine.**

In case of electric motor use, please refer to the specific supplied guide.

The main features of the Lady blowing machine are listed below:

- Weight: approximately 6 kg
- Compact dimensions: 253 x 224 x 140 mm
- Use temperature -10 °C / +60 °C
- Digital display with operative information (blow direction, speed, meter counter, compressed air pressure)
- Drive belt protection screens
- Cable diameters: 1,2 ÷ 10 mm
- Minitubes diameters: 5 ÷ 16 mm

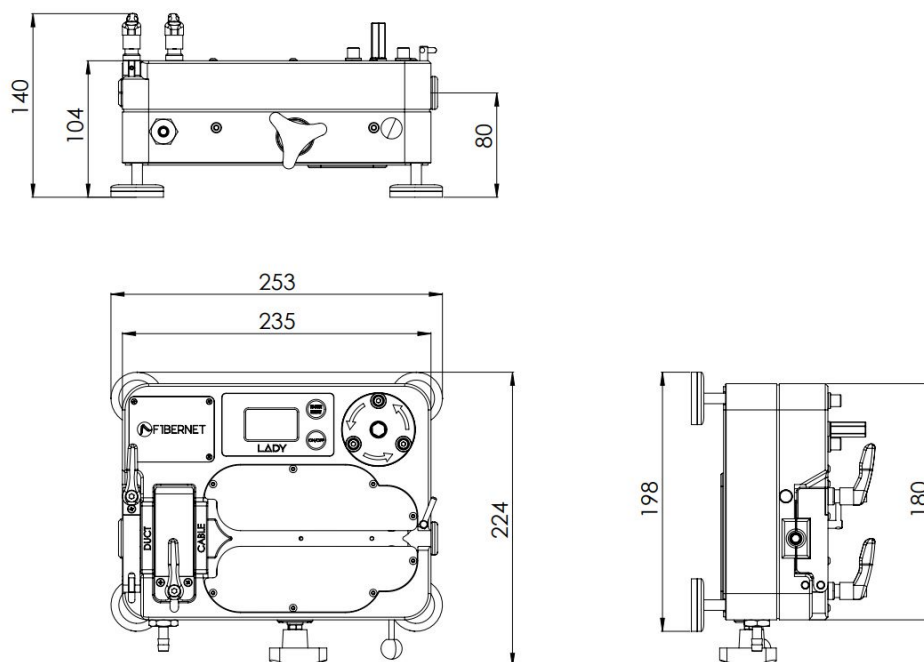

Figure 2: Lady – External dimensions.

FIBERNET SRL

Headquarters: Via degli Olmetti, 18 – 00060 Formello (RM) - Italy  
 Share Capital € 100.000,00 - P.I. e C.F.: 06557181002 - Tel. +39 06 90405039  
[www.fibernet.it](http://www.fibernet.it); E-mail: [info@fibernet.it](mailto:info@fibernet.it)

## 2.1. PRODUCT CONFIGURATION

To ensure greater sturdiness and reliability, the device is made of only two anticorrosive aluminum bodies designed to contain all the mechanic and the electronic parts required for a proper functioning.

Below listed the main blowing machine constituent parts (Figure 3.)

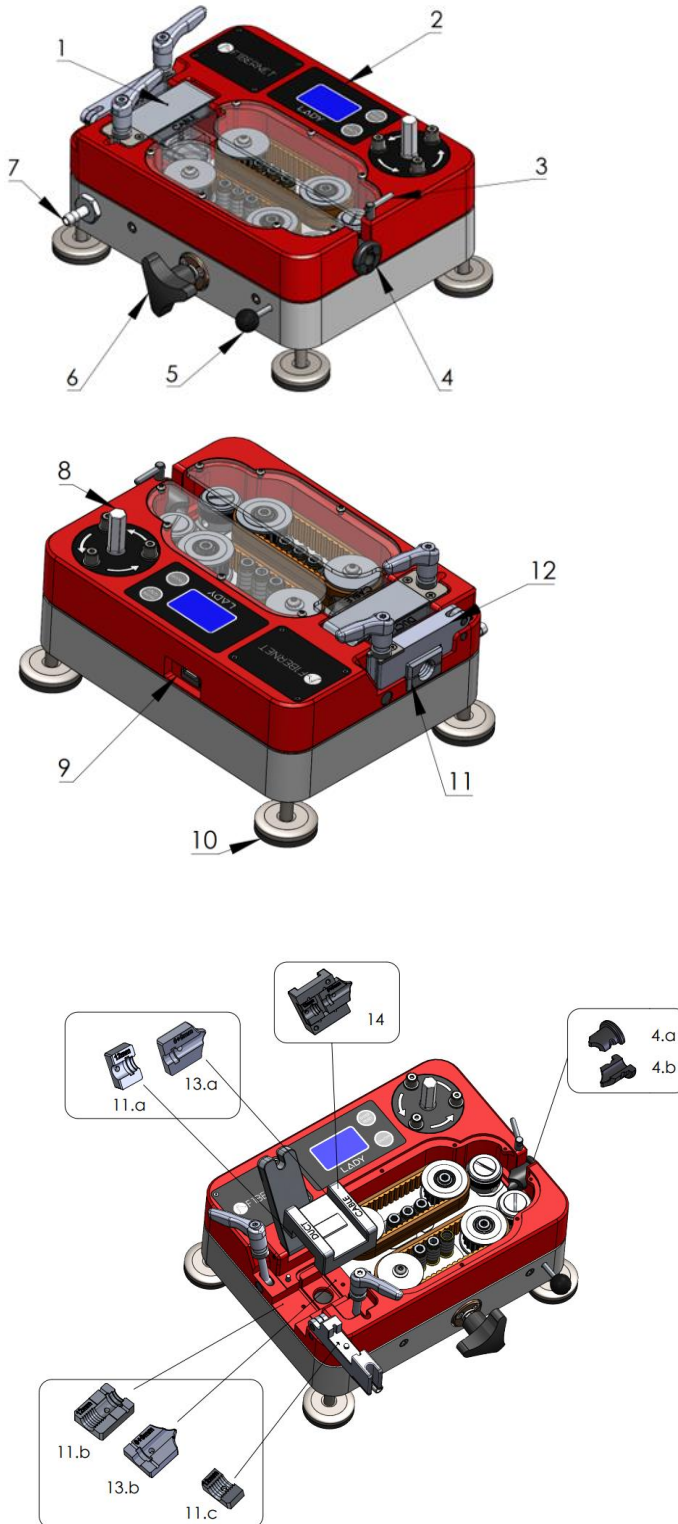

Number	Elements' name
1	Air lid
2	LCD Display
3	Cable entry adapter fixing lever
4	Cable entry
4.a	Upper cable entry adapter
4.b	Lower cable entry adapter
5	Meter counter wheel opening knob
6	Drive belts pressure regulation knob
7	Compressed air connector
8	Electric screwdriver connector
9	USB plug
10	Adjustable pin
11	Minitube adapter kit
11.a	Upper minitube adapter
11.b	Lower minitube adapter
11.c	Minitube fixing adapter
12	Minitube fixing clamp
13	Cable adapter kit
13.a	Upper cable adapter
13.b	Lower cable adapter
14	Air clamp

Figure 3: list of parts.

FIBERNET SRL

Headquarters: Via degli Olmetti, 18 – 00060 Formello (RM) - Italy  
 Share Capital € 100.000,00 - P.I. e C.F.: 06557181002 - Tel. +39 06 90405039  
[www.fibernet.it](http://www.fibernet.it); E mail: [info@fibernet.it](mailto:info@fibernet.it)

## 2.2. ACCESSORY KIT

The device is provided with the following accessories:

Description	Quantity	Pictures
Lubricant for minitubes	1 L	
USB cable	1	
2 mm, 3 mm and 8 mm hex wrenches	1	
½" to 3/8" junction	1	
Air hose and valve	1	
Microduct cutter	1	
Linear gasket Ø 3 mm	0,5 m	
Utensil bag	1	
Waterproof polipropylene case	1	

FIBERNET SRL

Headquarters: Via degli Olmetti, 18 – 00060 Formello (RM) - Italy  
 Share Capital € 100.000,00 - P.I. e C.F.: 06557181002 - Tel. +39 06 90405039  
[www.fibernet.it](http://www.fibernet.it); E-mail: [info@fibernet.it](mailto:info@fibernet.it)



## Adapters kit:

Description	Quantity	Pictures
Duct adapters kit at customer's choice (included in Lady's price)	1+1+1	
5 mm duct gasket 7 mm duct gasket 8 mm duct gasket 10 mm duct gasket 12 mm duct gasket 14 mm duct gasket 16 mm duct gasket	1 Set	
Cable adapters at customer's choice (included in Lady's price)	1+1	
1-10 mm cable gasket	1 Set	
Cable entry adapters	1+1	
Other adapters kits are to be required separately	See "Accessories list & spare parts"	

Table 1: accessories kit.



### 3. OPERATING INSTRUCTION

Listed below the procedures to follow for a proper machine use.

They are divided in:

- 3.1 Preliminary operations
- 3.2 Posing procedure with compressed air
- 3.3 Cable posing
- 3.4 Cable posing in an intermediate stop

#### 3.1. PRELIMINARY OPERATIONS

Before getting started it is recommended to verify that the minitube is clean and dry in the inside (for this purpose we recommend to use compressed air inside the tube to eliminate any solid or liquid residues).

To ease the blowing operation, use the lubricant (provided among the accessories kit) following the amounts listed in Table 2 shown below:

internal diameter of minitube [mm]	Lubricant approximate quantity per 1000 m	
	Volume [ml]	Minitube filling height [cm]
4	10	78 ÷ 82
8	18	35 ÷ 38
10	23	29 ÷ 32
12	27	24 ÷ 26

Table 2: correspondence between minitube diameter and lubricant quantity

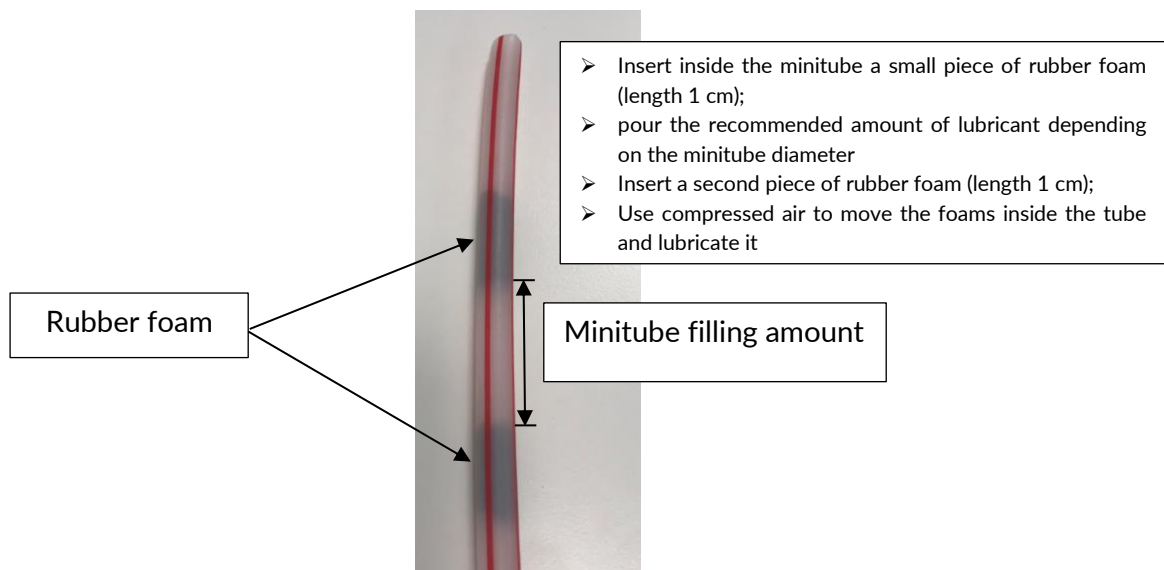

Figure 4: minitube lubricant filling example.

### 3.2. POSING PROCEDURE WITH COMPRESSED AIR

Use Lady with the aid of compressed air to minimize friction between cable and minitube. Air pressure shall not exceed 16 bar. Below listed the instructions to follow.

#### 3.2.1. CABLE AND DUCT POSITIONING

Connecting the minitube to the device:

- a. Choose from the accessory kit the proper duct gasket and insert it on the minitube.



Figure 5: duct gasket insertion.

- b. Open the "minitube fixing adapter" (11.c), open the "air lid" (1), lift the "Air clamp" and set the minitube onto the "lower minitube adapter" (11.b) making sure that it is inserted till the end and that the duct gasket is correctly inserted.



Figure 6: minitube proper insertion.

- c. Close the "minitube fixing adapter" (11.c) using the "minitube fixing clamp" (12).

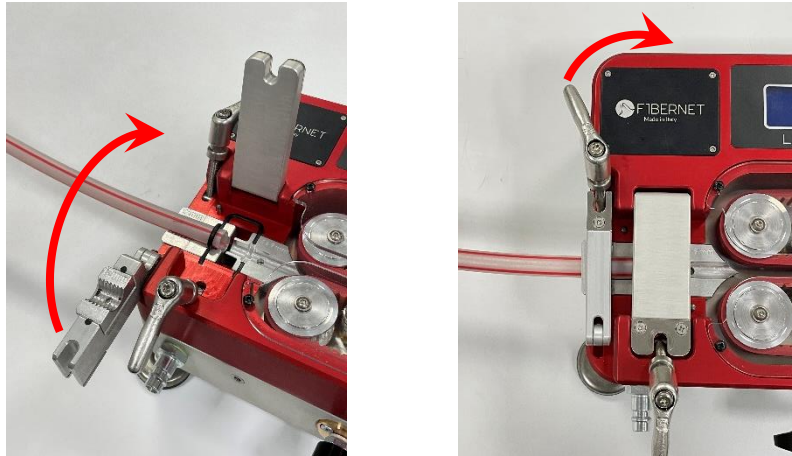

Figure 7: closing the minitube fixing clamp

Inserting the fiber optic cable:

- d. Set the right cable gasket according to the cable diameter, making sure that the “lip” side is facing the minitube.

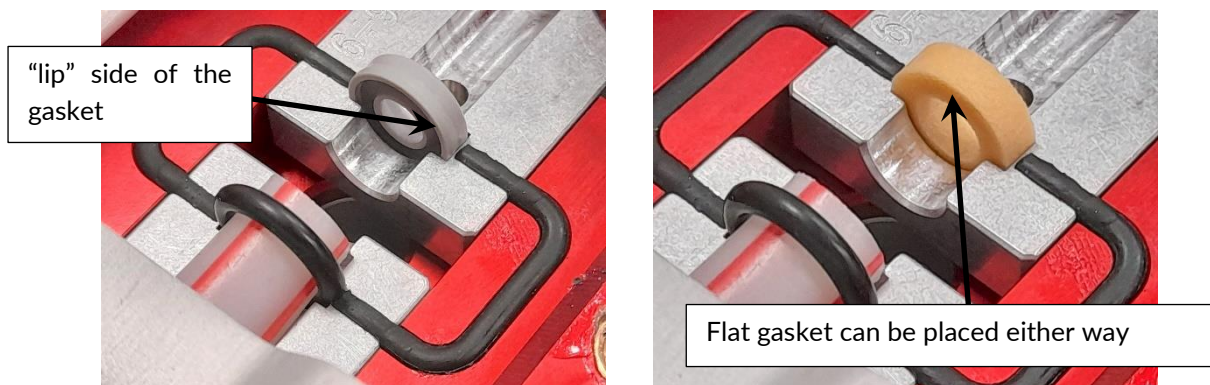

Figure 8: Proper positioning of lip and flat gasket

Round the head of the cable (with a heat source) to avoid catching edges in correspondence of the minitube joints.



- e. Set pressure between cable and drive belts using the “drive belts pressure regulation knob” (6) insert the cable inside the “cable entry” (4) and into the lip gasket.

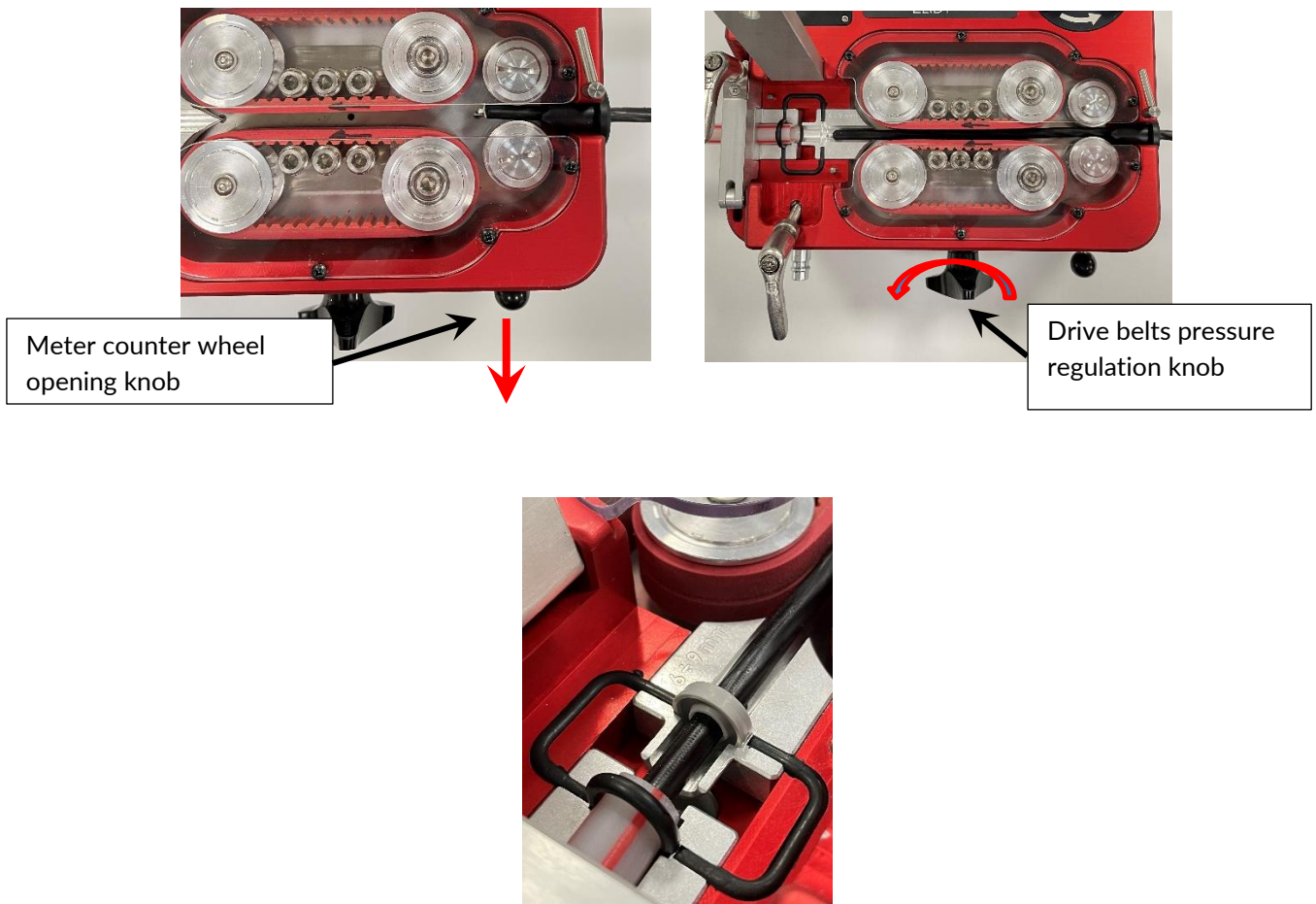

Figure 9: Setting belts distance and cable insertion inside lip gasket

- g. Insert the Air clamp with the adapters into the dowel pins  
 h. Close the “air lid” (1) using the specific lever





Figura 10: closing the air lid



**AIR PRESSURE HAZARD: do not open air lid while operating with compressed air**

- i. Set pressure between cable and drive belts using the “*drive belts pressure regulation knob*” (6) to have a good grip and avoid cable slipping during operation.

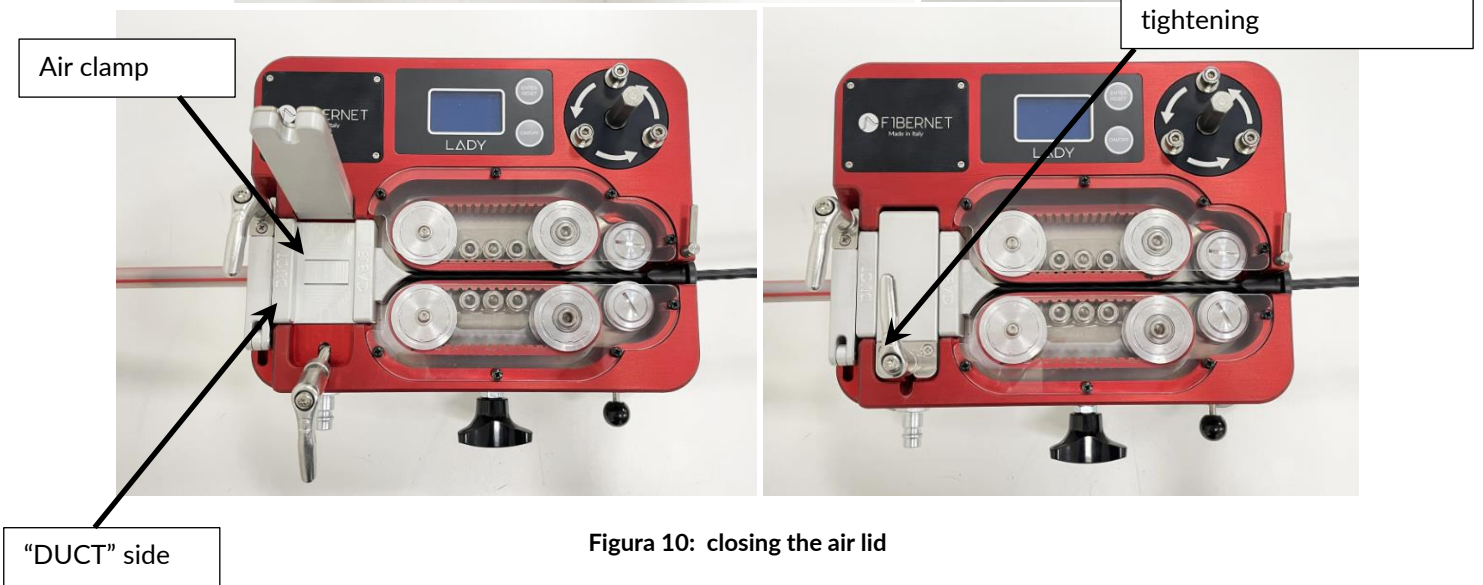
### 3.2.2. AIR COMPRESSOR CONNECTION

After having positioned the minitube, the cable and their gaskets, connect the air hose to the “compressed air connector” (7).



Figure 11: connecting the air hose to the compressed air connector



**NOTE:** Compressed air helps reduce friction inside the minitube. We recommend to increase pressure gradually once you started the machine.



**MAXIMUM AIR PRESSURE SHALL NOT EXCEED 16 BAR**

### 3.3. CABLE POSING

After having connected all the above mentioned components, you can proceed by lighting up the display by pushing the “ON/OFF” button (menu instructions are listed in paragraph 3.6)

To pose the cable:

- Connect the electric screwdriver spindle equipped with a clutch to the “electric screwdriver connector” (8).



we recommend inserting a 10 mm male hex socket in the electric screwdriver

FIBERNET SRL

Headquarters: Via degli Olmetti, 18 – 00060 Formello (RM) - Italy  
 Share Capital € 100.000,00 - P.I. e C.F.: 06557181002 - Tel. +39 06 90405039  
[www.fibernet.it](http://www.fibernet.it); E mail: [info@fibernet.it](mailto:info@fibernet.it)



Figure 12: connecting the electric screwdriver.

NOTE: Lady can be actioned by an electric or pneumatic motor. Respective manuals are provided according to the type of motor chosen.



**ATTENTION: MAKE SURE THAT THE DIRECTION OF ROTATION OF THE ELECTRIC SCREWDRIVER IS SET COUNTER-CLOCKWISE AS SHOWN ON THE “ELECTRIC SCREWDRIVER CONNECTOR “**



Direction of rotation

Figure 13: Direction of rotation of the electric screwdriver spindle

- Start the electric screwdriver keeping an eye contact on the “LCD display” (2) while making sure that the cable is properly moving between the drive belts.



**ATTENTION: STOP THE DEVICE IF YOU SEE THAT THE CABLE IS NOT MOVING TO AVOID POSSIBLE DAMAGE TO THE CABLE OR TO THE MACHINE**



### 3.4. CABLE POSING IN AN INTERMEDIATE STOP

When the blowing operation stops between two cockpits a possible solution is to intervene in an intermediate cockpit, intercepting the tube without interrupting cable's continuity.

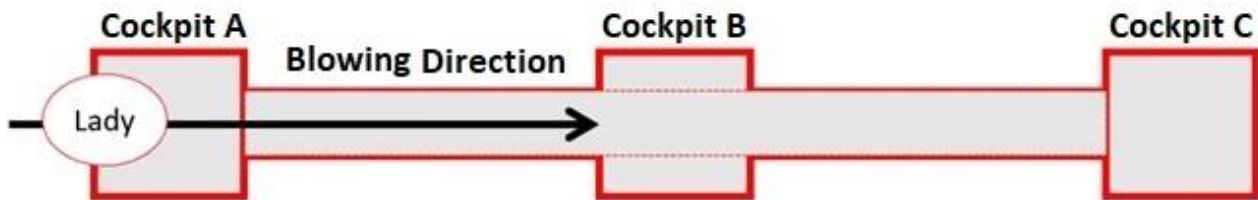

Figure 14: initial situation.

Lady set in proximity of cockpit A, blows cable toward cockpit C.

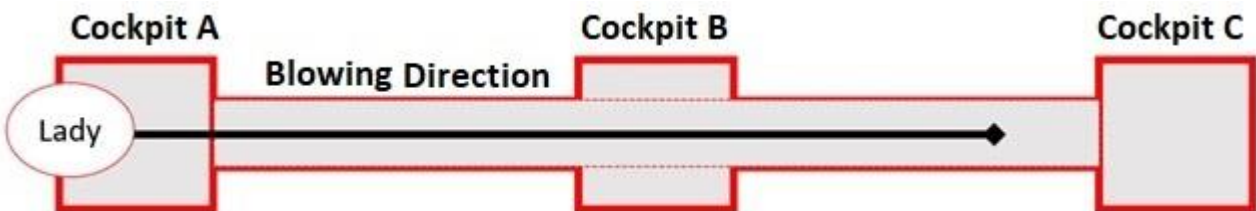

Figure 15: cable pose interrupted.

Passed the intermediate cockpit B, blowing operation stops before reaching cockpit C.

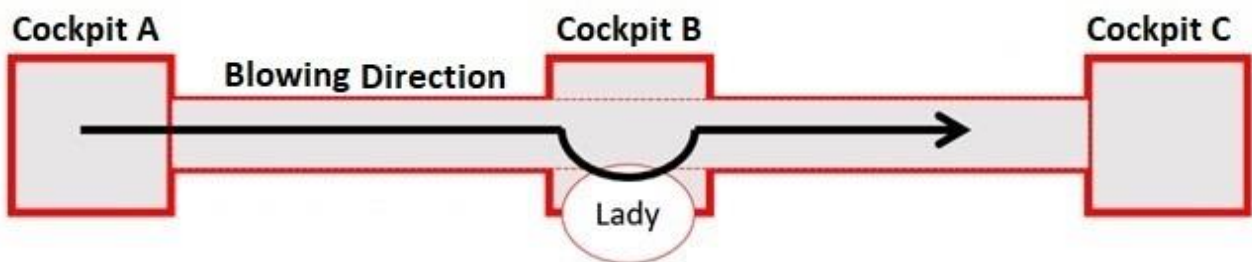

Figure 16: Open cockpit B, place lady in this intermediate cockpit and continue operation.

It is possible to resume the operation intercepting the tube and inserting the cable back again assuring continuity.

Inserting cable in continuity in the blowing machine:

- Extract the "upper cable entry adapter" (4.a) turning the "cable entry adapter fixing lever" (3).

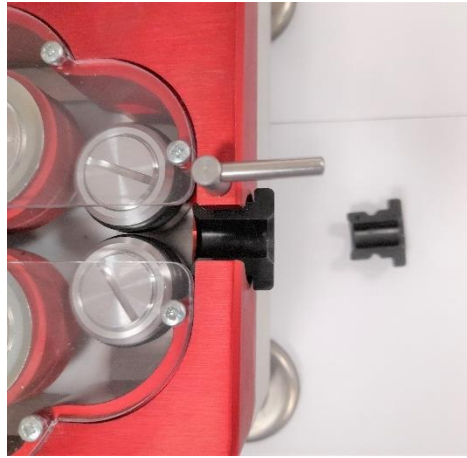

Figure 17: Open the cable entry adapter kit turning the lever outwards

- Open the "air lid" (1) and the "minitube fixing clamp" (12).
- With a pair of scissors cut diagonally both cable and duct gasket.



Figure 18: cut gaskets diagonally.

- Now insert both gaskets on the corresponding component

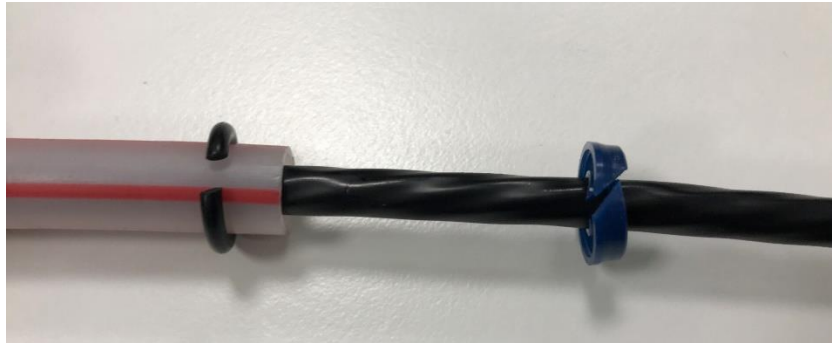

Figure 19: inserting diagonally cut gaskets.

- Set cable and minitube inside the device, positioning the gaskets with cut facing down, for a better fit, as shown in figure 24.



Figure 20: positioning the gaskets with cut facing down

- Set pressure between cable and drive belts using the “drive belts pressure regulation knob” (6).
- Insert the cable inside the “cable entry” (4) pulling the “meter counter wheel opening lever” (5).



Figure 21: pulling the meter counter wheel opening lever to insert the cable

- Closing the “cable entry kit” (4): set the “upper cable entry adapter” (4.a) and fix it by turning the “cable entry adapter fixing lever” (3) inward.

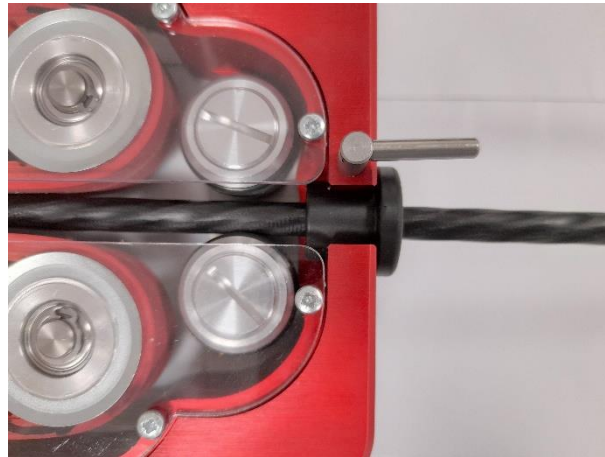

Figure 22: cable insertion inside cable adapter kit.

- Finish the operation following the above-mentioned steps.

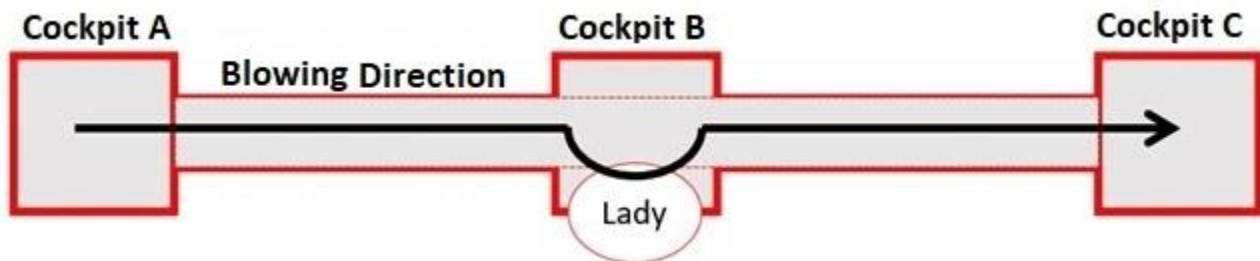

Figure 23: operation completed.

### 3.5. DISPLAY INFORMATION

In Figure 28 the detailed information shown on display

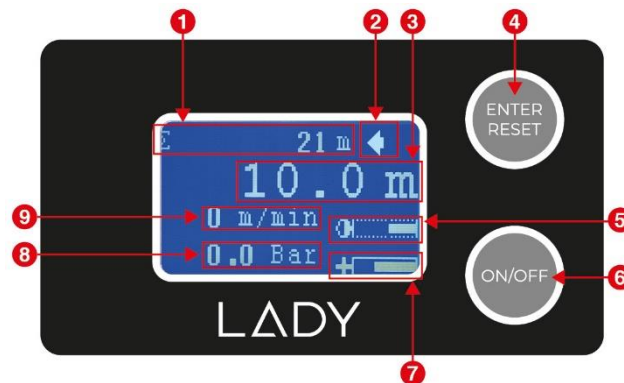

Figure 24: configuration of the Display

Position	Name	Description
1	General meter counter	Shows the total distance expressed in meters of cable blown from the first ignition
2	Direction	Shows the direction in which the cable is been blown
3	Partial meter counter	Shows the distance expressed in meters from last reset
4	Menu navigation button ENTER/RESET	It allows you to navigate in the menu
5	Contrast level	Shows the display contrast level
6	ON/OFF button	Turns on and off the display
7	Battery charge level	Shows battery level
8	Air pressure	Shows the air pressure expressed in bar flowing inside the minitube
9	Speed	Shows blowing speed expressed in m/min

Table 3: list of information shown on display.

The display works with a highly performing and long-lasting lithium battery. For substitution see paragraph 4.4.

Below listed the operations doable with the display:

- a. **Turning it on:** push "ON/OFF" button.
- b. **Turning it off:** keep the "ON/OFF" button down for 5 seconds
- c. **Resetting the partial meter counter:** push the "ENTER/RESET" button and scroll until you find "Partial meter counter"; keep button down for 5 seconds until the writing turns white, then push again the button for 5 seconds to check the correct reset.
- d. **Contrast regulation:** push the "ENTER/RESET" button and scroll until you find "Contrast level". Keep button down for 5 seconds until the "ENTER/RESET" button lights up, push button "ENTER/RESET" to increase contrast or the "ON/OFF" button to decrease it.

After a few seconds of inactivity the display returns to its initial selection page.

### 3.6. DRIVE BELTS HANDLING

Below listed the details to properly handle the drive belts:

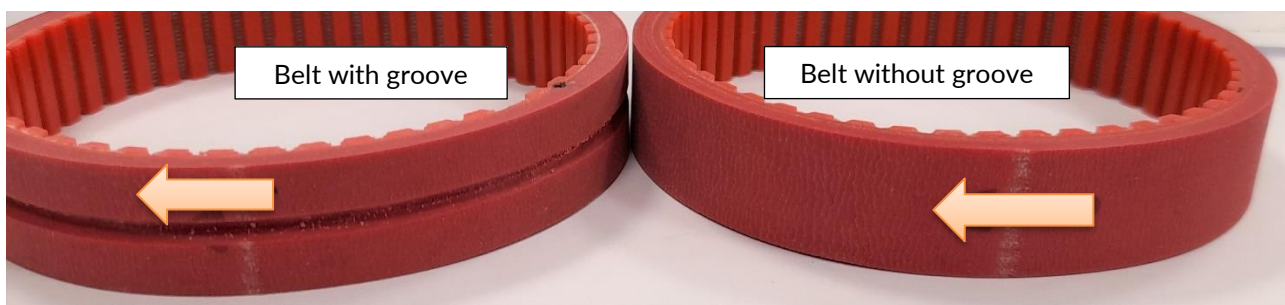
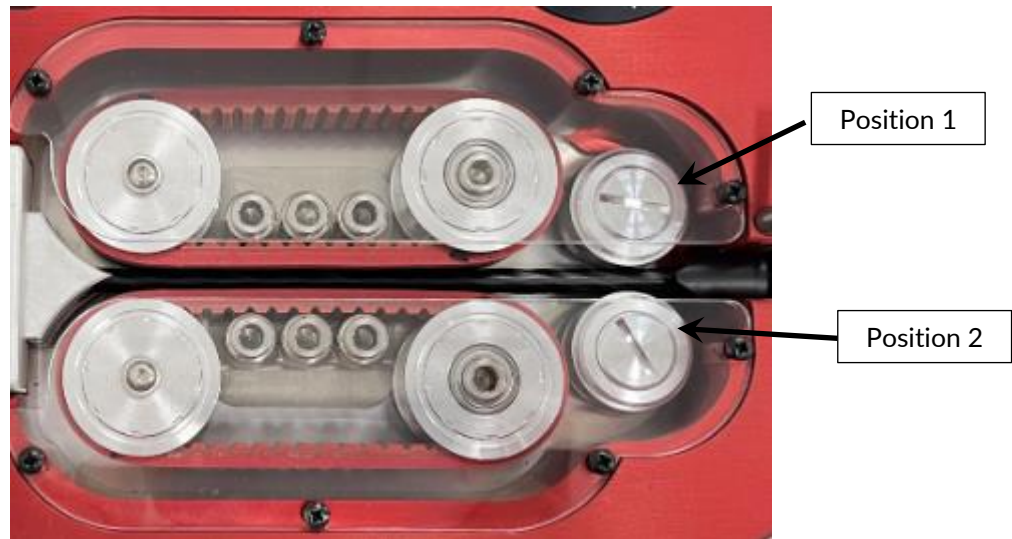

- For cables with  $\varnothing \geq 2$  mm – use the belts with groove
- For cables with  $\varnothing < 2$  mm – use belt with groove in position 1 and without groove in position 2

NOTE: During belts substitution (see paragraph 4.2) make sure to mount them in the right direction because the blowing operation has to be performed in accordance to the cable's direction.



## 4. MAINTENANCE

For an optimal maintenance we recommend following the listed instructions:

1. Cleaning
2. Drive belts substitution (extraordinary maintenance)
3. Adapter gaskets substitution
4. Recharging the lithium display battery

We recommend cleaning the device after every use using compressed air.

### 4.1. CLEANING

Using the device in inappropriate conditions (dust and rain) may cause damage to it, in particular:

- Affect the electronic board correct functioning
- Decrease friction and wear down the drive belts
- Cause the meter counter wheels to slide and distort the measurements
- Sliding difficulty in the belts' cart

### 4.2. DRIVE BELTS SUBSTITUTION

Belts substitution has to be performed only in exceptional circumstances in particular when clear signs of wear or damage are visible or when sliding events manifest during blowing operations due to great usury of the belts.

Below listed instructions for belts substitution:

1. Remove the two plexiglass protections put on top of the device removing the screws that fix them to the chassis.

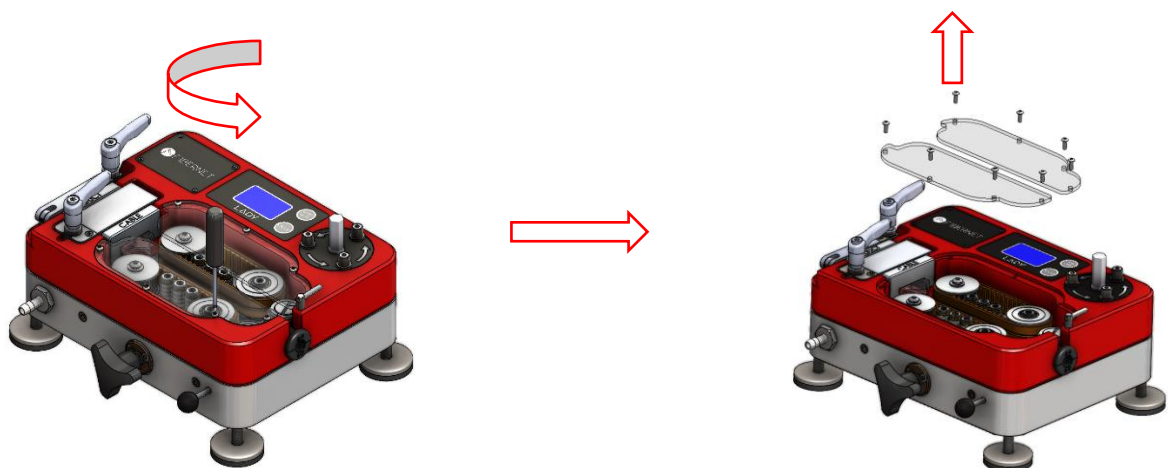

Figure 25: removing the two plexiglass protections.



- Remove the bottom lid unscrewing the 4 screws on the edges of the cover using a size 2 Allen key.

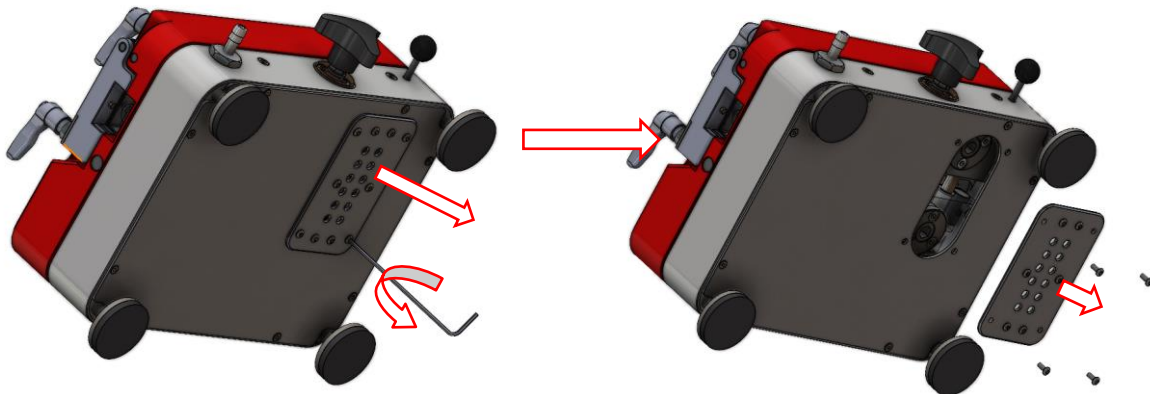

Figure 26: removing the bottom lid.

- Loosen (**do not remove**) the three hex screws with a 3 mm hex wrench (provided among the accessories)

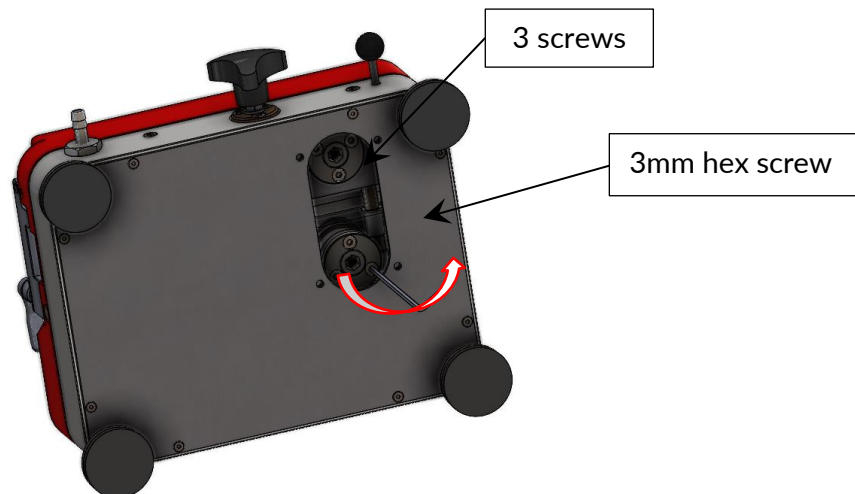

Figure 27: three hex screws to loosen up

- Insert the 8mm hex wrench (provided among the accessories) in the pulley's middle hole. Unscrew a quarter turn ( $45^\circ$ ) in order to move closer the stable pulley to the loosen one and be able to substitute the drive belt.

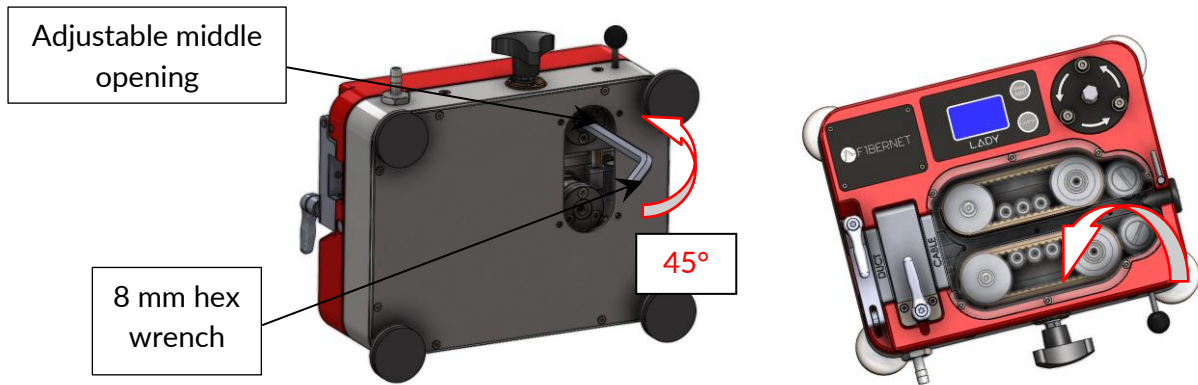

Figure 28: necessary steps to remove the drive belts.

- Repeat procedure to remove the second drive belt.

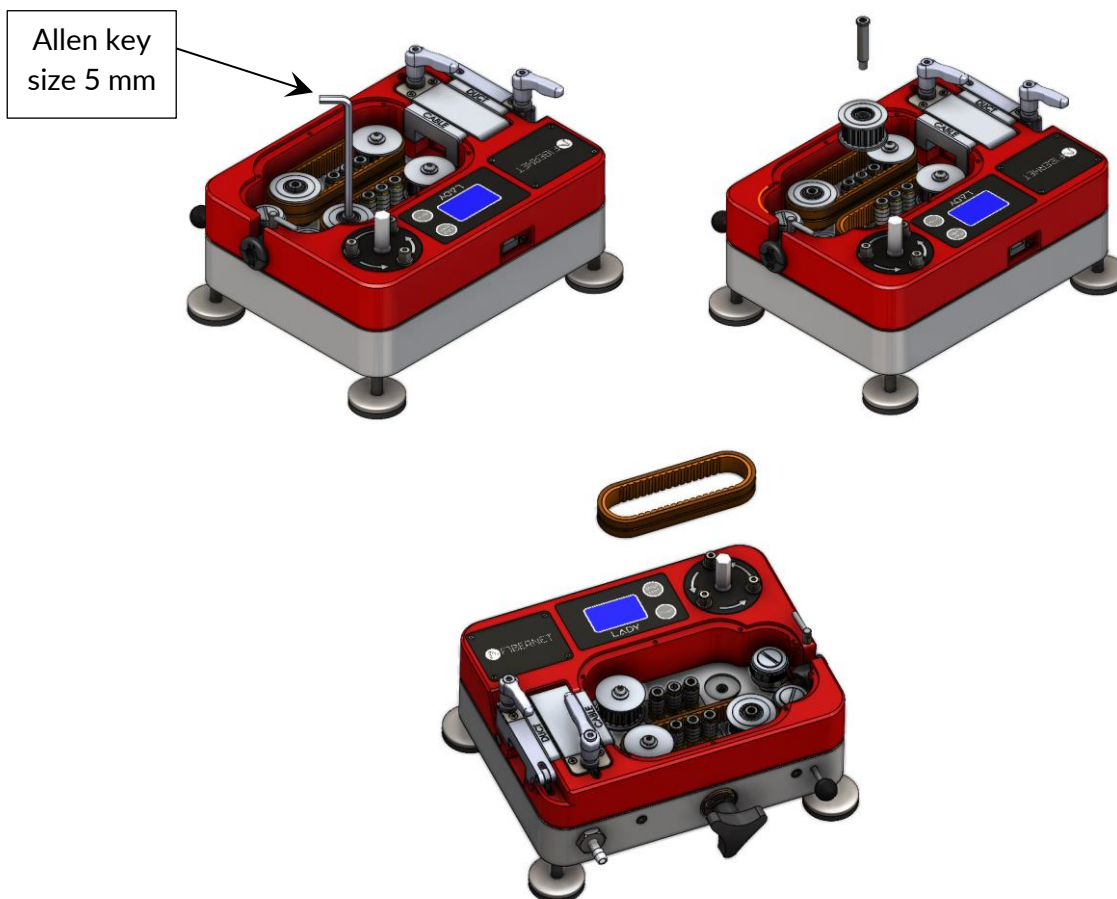

Figure 29: extracting the drive belt.

- Set the new drive belts onto the two pulleys and repeat the above-described procedure backwards and tighten up the belts screwing the loosen pulley.
- Tighten the 3 hexagonal head screws of the released pulley with the 3mm Allen key (provided) and replace the cover on the underside of the blower machine.
- Fix the plexiglass protections.

Note: in case you have difficulties extracting the drive belts you can remove the elastic bands that block them.

### 4.3. SEAL ADAPTER GASKETS SUBSTITUTION

We recommend substituting the pre-assembled gaskets when you notice excessive air pressure losses when using compressed air. Below a list of the linear gaskets that can wear down:

- 2 pcs in the upper section of the "air lid" (1)
- 2 pcs in the lower section of the "air lid" (1) (not visible with the adapters mounted)
- 2 pcs in the lower section of the "air lid" (1) (visible with the adapters mounted)

The linear substitution gasket is provided among the given accessories.

The procedure to follow is below described:

1. In order to substitute the lower gaskets remove the "lower minitube adapter" (11.b) and the "lower cable adapter" (13.b); to substitute the upper gaskets remove the "upper minitube adapter" (11.a) and the "upper cable adapter" (13.a). Afterwards remove the worn out gasket.

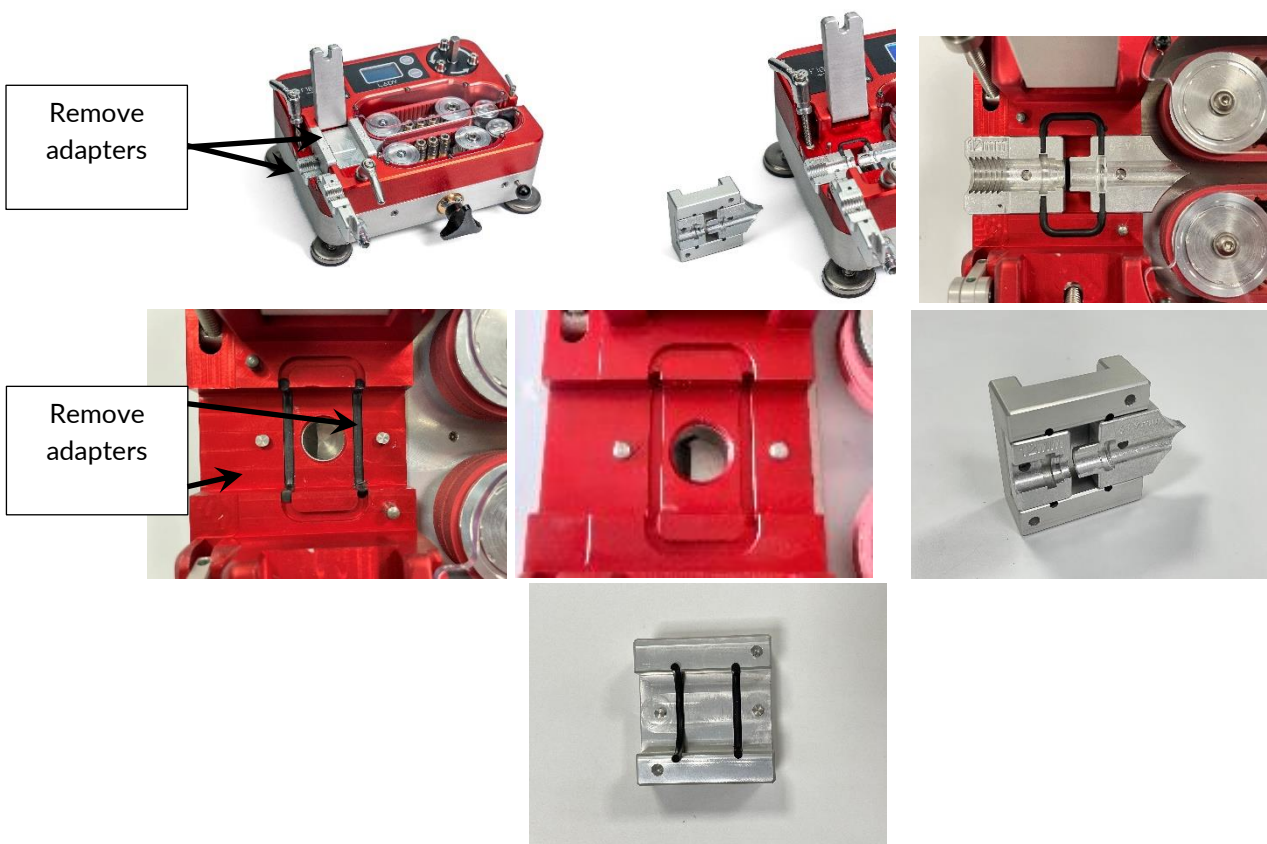

Figure 30: Unmounting adapters to remove gaskets

2. Cut the  $\varnothing 3$  mm linear gasket as shown below (5 cm).



Completed assembly

Figure 31: cutting the linear gasket.

3. Insert the new gaskets in their proper housing and mount back all adapters (11.a, 11.b, 13.a, 13.b).

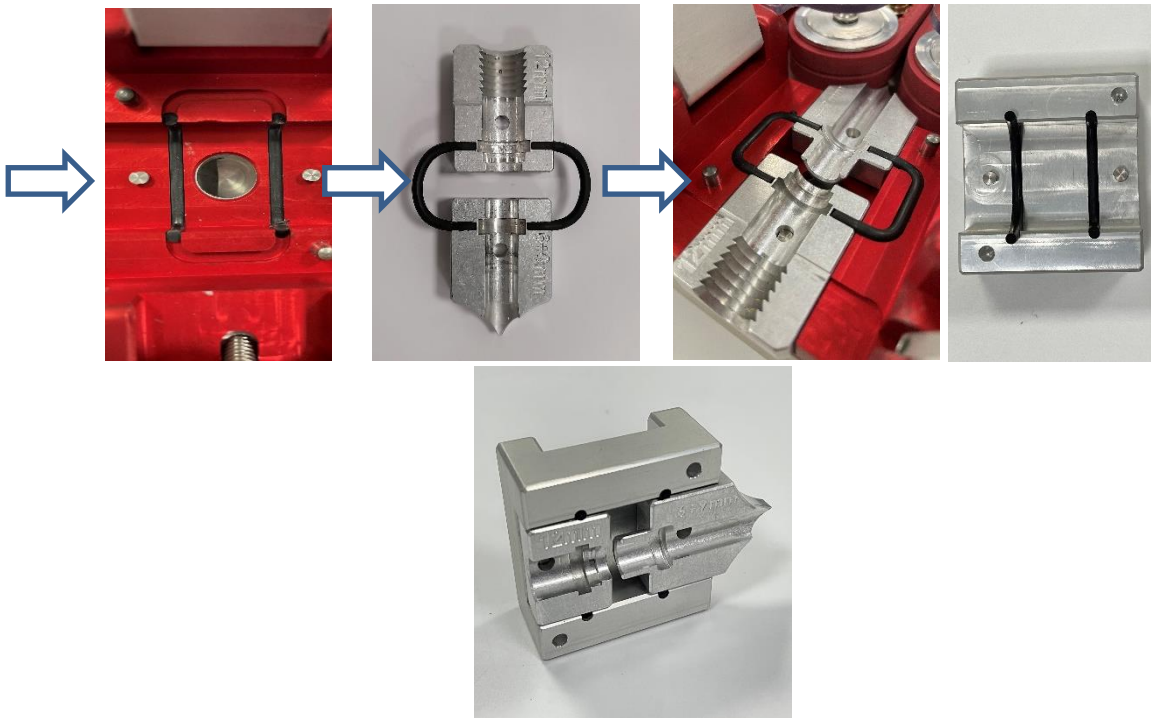
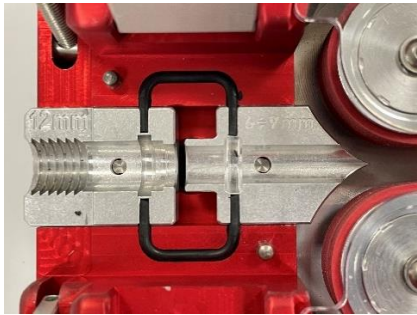
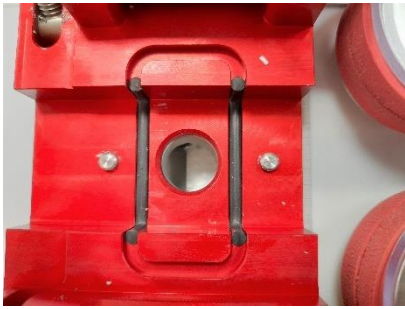
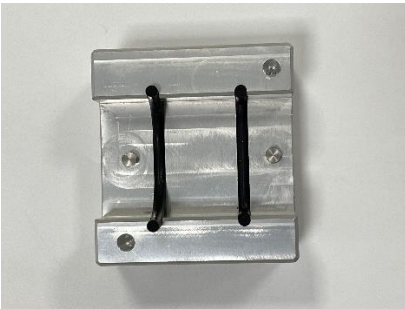



Figure 32: mounting the new gaskets.

Summary of  $\varnothing$  3 mm linear gasket lengths: (suitable for every cable adapter):

Pos.:	Detail:	$\varnothing$ 3 mm linear gasket length		
		Pos.:	external $\varnothing$ of mini-tube (mm):	length in mm of the 2 pieces
1		1	16	47,0
		2	14	47,5
		3	12	48,5
		4	10	49,5
		5	8	50,0
		6	7	50,5
		7	5	51,5



2		2 pieces of 50 mm
3		2 pieces of 50 mm
4		2 pieces of 10 mm (*)

(\*) - NOTE: This gasket does not affect the pneumatic hold, its only purpose is to keep the adapter in place.

#### 4.4. BATTERY RECHARGING

When the "LCD Display" shows that the battery is running out, it is necessary to recharge it using the USB cable. We recommend using a power bank of at least 2000 mA to recharge the battery (do not use a personal computer USB port).

Battery life is approximately 20 hours.



**DO NOT USE A PERSONAL COMPUTER USB PORT**



**NOTE: WE RECOMMEND USING A POWER BANK OF AT LEAST 2000 mA TO RECHARGE THE BATTERY**

How to open the battery lid for the substitution:



remove the 4 screws



Battery Compartment Seal

## 5. CE DECLARATION OF CONFORMITY

**Dichiarazione di conformità**

*CE declaration of conformity  
Déclaration CE de conformité  
CE konformitätserklärung*

**Il fabbricante:**

*The manufacture:  
Le fabricant:  
Der Hersteller:*

**FIBERNET Srl  
Via degli Olmetti,18 – 00060 Formello,(RM) - ITALY**

**Il fabbricante con la presente dichiara che,**

*The manufacturer hereby declares that,  
Le fabricant déclare par la présente que,  
Der Hersteller erklärt hiermit, dass,*

**Il dispositivo per la posa dei cavi mediante "Jetting"**

*The device for laying cables by "Jetting"  
Appareil pour la pose de cables par "Jetting"  
Vorrichtung zum Verlegen von Kabeln durch " Jetting "*

Type  
Anno/Année/Year/Jahr

**FIBERNET LADY**

**2020**

**Il prodotto sopra identificato è conforme alle seguenti direttive e standard:**

*The above identified product is compliant with the following directives and standards:*

*Le produit identifié ci-dessus est conforme aux directives et normes suivantes:*

*Das oben angegebene Produkt entspricht den folgenden Richtlinien und Standards:*

- Machine directive **2006/42/EC**
- Directive **2014/30/EU** Electromagnetic compatibility
- Directive **2014/35/EU** LVD

**Norme armonizzate applicate:**

*Harmonized standards applied:*

*Normes harmonisées appliquées:*

*Angewandte harmonisierte Normen*

- Standard EN ISO12100:2010 /Safety of machinery - General principles for design - Risk assessment and risk reduction
- Standard CEI EN55011: 2018 / Limits and methods of measurement for radio disturbance characteristics of ISM Equipment: Conducted and Radiated emissions
- Standard CEI EN61010-1:2013 / Safety requirements for electrical equipment for measurement, control and laboratory use

Roma 08/08/2020

Quality System Manager

**Fibernet Srl**

Via degli Olmetti, 18 - 00060 Formello, Roma  
Tel. +39 06 90.40.50.39 - Fax +39 06 90.40.92.66 - P.iva 06557181002  
web@fibernet.it - http://www.fibernet.it/

**FIBERNET SRL**

**Headquarters:** Via degli Olmetti,18 – 00060 Formello (RM) - Italy  
Share Capital € 100.000,00 - P.I. e C.F.: 06557181002 - Tel. +39 06 90405039  
[www.fibernet.it](http://www.fibernet.it); E-mail: [info@fibernet.it](mailto:info@fibernet.it)